

# ArduinoUNO Based Robot

Motor Driver: Half Bridge Darlington ULN2803 TTL/5VCMOS

Perception: Sharp GP2D120XJ00F, UGN3503, TMP35, LDR

Robot Type: Mobile Differential - Unidirectional Movement

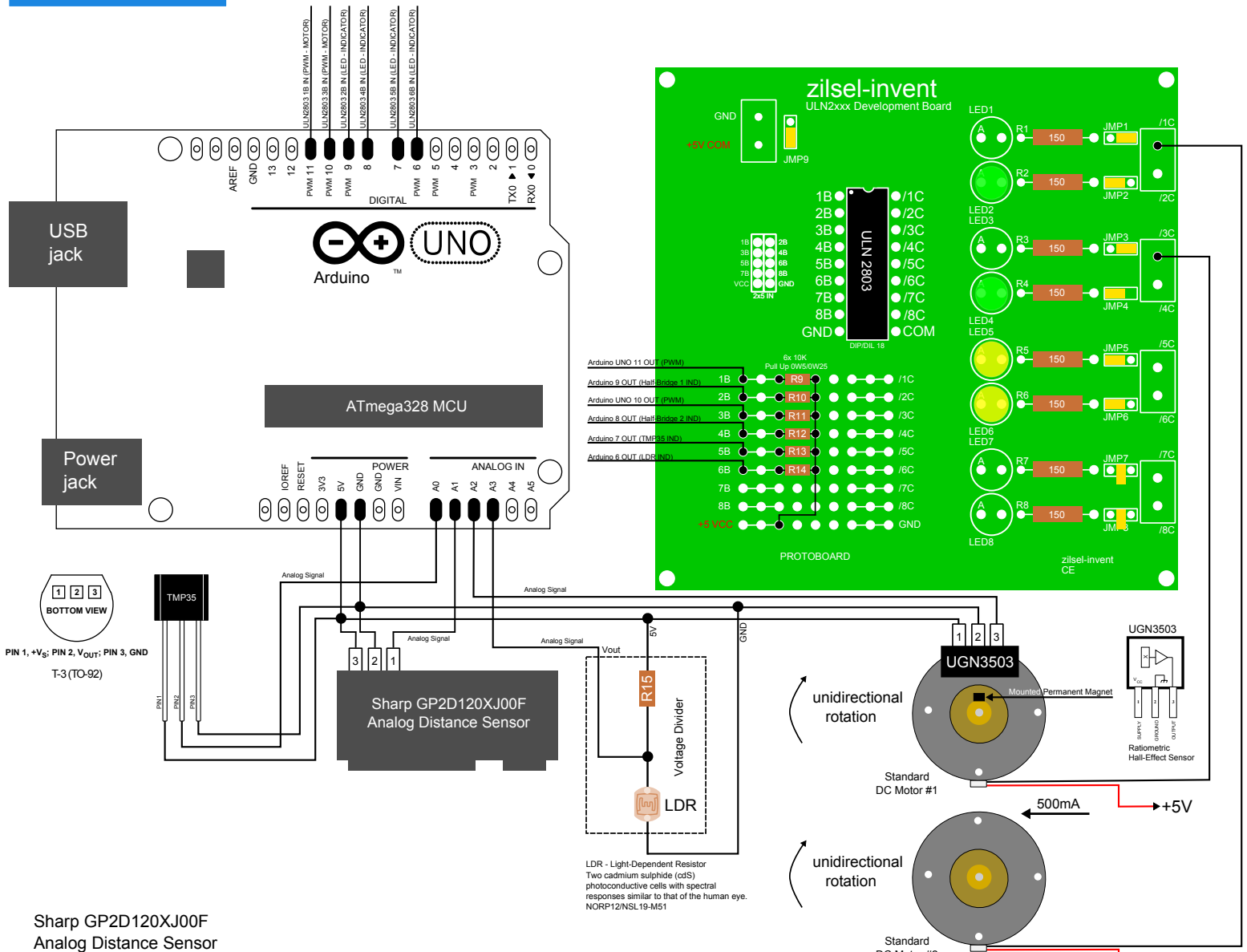

Sharp GP2D120XJ00F  
Analog Distance Sensor

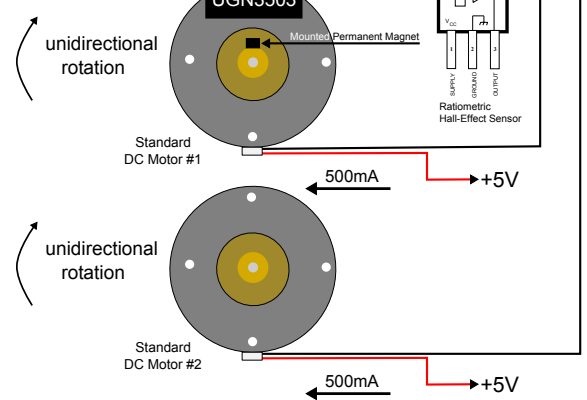
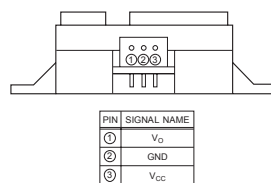
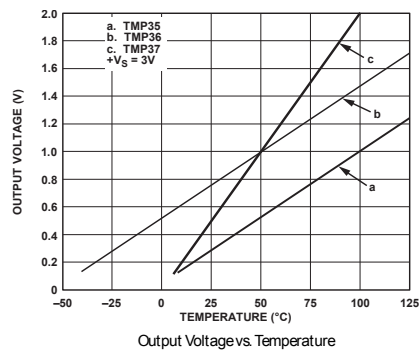
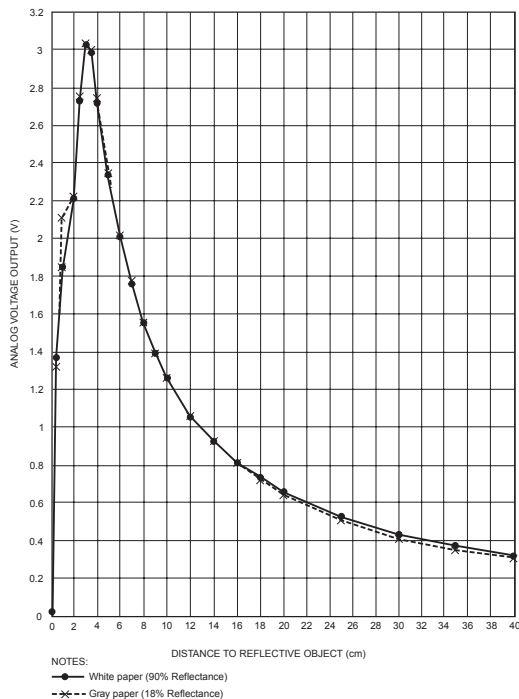

2x Gearmotor 90-Degree  
Operating Voltage Range: 3.0 - 12.0V

DC Motor Control Signals:

- Arduino Pin11 (OFF), Pin10 (OFF) -> Stop
- Arduino Pin11 (ON), Pin10 (OFF) -> Spin (direction1)
- Arduino Pin11 (OFF), Pin10 (ON) -> Reverse Spin (direction2)
- Arduino Pin11 (ON), Pin10 (ON) -> Forward movement

Mobile Differential Robot

