

ArduinoUNO Based Robot

H-Bridge Motor Driver: BA6222

Perception (Sensor): Sharp GP2D120XJ00F

Robot Type: Mobile Differential

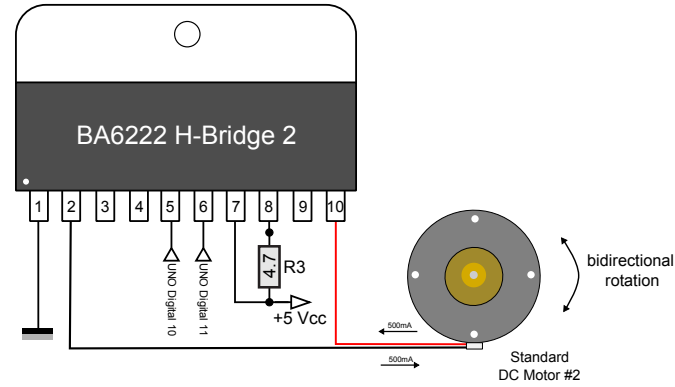
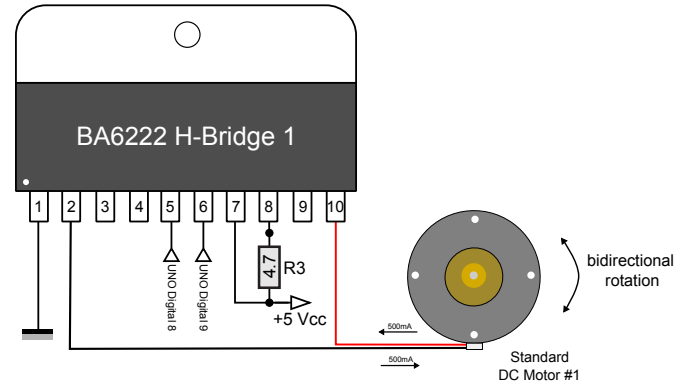
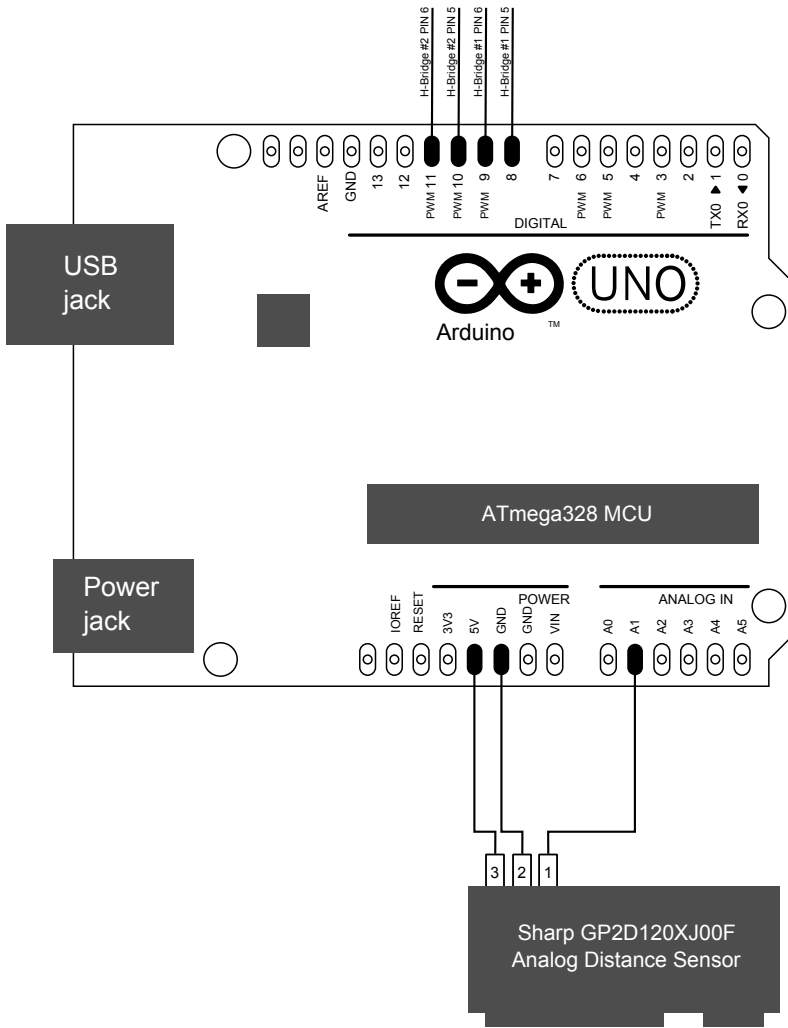

Sharp GP2D120XJ00F
Analog Distance Sensor

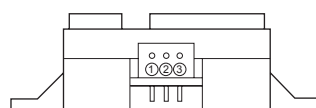
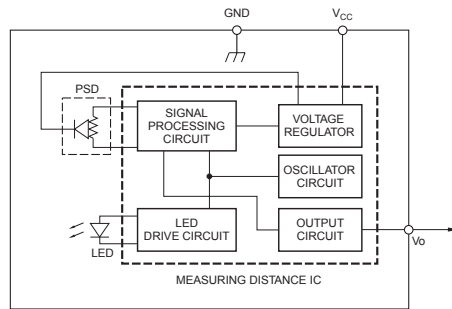
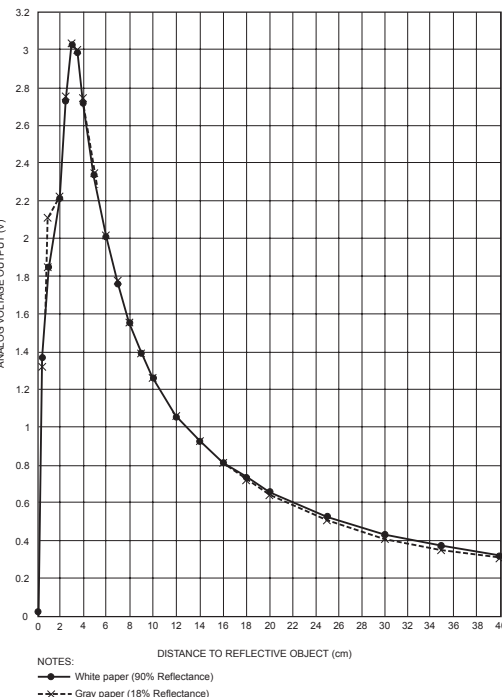

PIN	SIGNAL NAME
①	V _o
②	GND
③	V _{cc}

BA6222 H-Bridge:

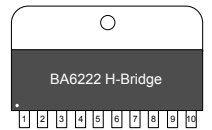

F Input / output truth table

5pin (IN)	6pin (IN)	2pin (OUT)	10pin (OUT)
L	L	OPEN	OPEN
H	L	H	L
L	H	L	H
H	H	L	L

Note: HIGH level input is 3.0 V or more
LOW level input is 1.0 V or less

Mobile Differential Robot

